

LYNX 32

VACUUM PACKAGING MACHINE



DESCRIPTION

The state-of-the-art Lynx 32 vacuum packaging machine is standard equipped with a Busch vacuum pump, Advanced Control System which is label printer compatible, Sensor control that ensures an optimum vacuum every cycle, and special marinating and packaging functions. This table-top model complies with CE standards.

FEATURES

- Standard with 1 seal bar (front): 320 mm
- Standard double seal (two wires). Optional without extra costs: Cut-off/Wide seal
- Seal bars easily removable for cleaning and maintenance purposes
- Pump capacity: 8 m³/h Busch vacuum pump
- Pump maintenance and cleaning program
- Machine cycle: 15-30 sec
- Standard Sensor control: max. 99.8%, for an optimum and consistent vacuum and cycle time
- Standard Soft Air to protect the product and vacuum bag
- Standard Advanced Control System with 20 program memory and Sensor control
- Stainless steel flat work plate and a transparent lid
- Comes with insert plate for a faster cycle and product adjustment
- Stainless steel exterior

OPTIONS

- Liquid control
- Gas flush
- High Temp to vacuum pack products at a high temperature

ACCESSORIES

- Zebra ZD410 thermal label printer
- Inclined insert plate (for packing liquids)
- Food container adaptor
- Service kit for standard maintenance
- Trolley with shelf



Henkelman offers standard 3 year warranty.

SEAL BAR CONFIGURATION



VACUUM PACAGKING MACHINE LYNX 32 – SPECS

DIMENSIONS

In mm

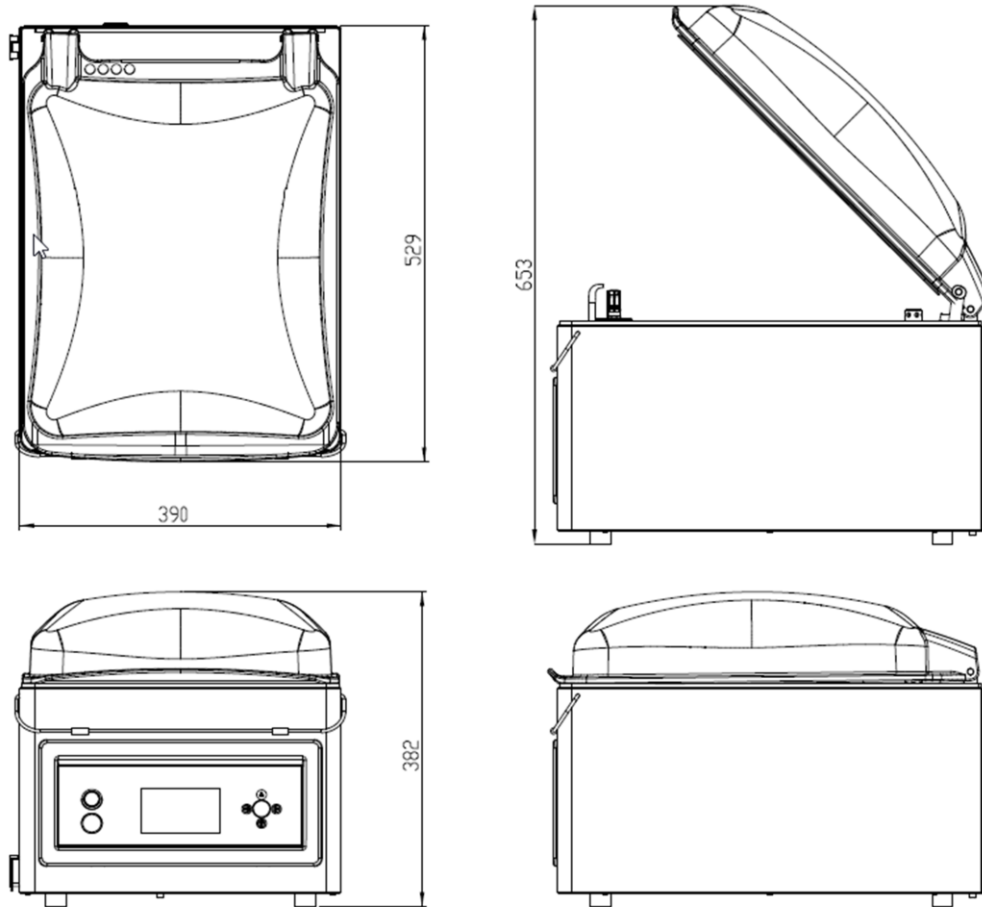

Model	Dimensions (mm)		Voltage* (Hz)	Pump capacity (m3/h)	Power (kW)	Weight (kg)
	Chamber (usable space) L x W x H	Machine L x W x H				
Lynx 32	360 x 320 x 103	529 x 390 x 382	230V-1-50	8	0,5	43

* Other voltages available



HENKELMAN BV
Titaniumlaan 10
5221 CK 's-Hertogenbosch
The Netherlands

Sales support
P +31 73 621 36 71
E info@henkelman.com
Service/technical support
P +31 73 621 36 71
E service@henkelman.com